

iRock-439T

Automatic Rockwell Hardness Tester

USAGE Instruction Manual

Content

One. Brief Introduction

Two. Main Parameters

Three. External Structure

Four. Working Condition

Five. Unpacking and Installation

Six. Operation Procedure

Seven. Interface Introduction and Usage

Eight. Attached List

Nine. Precautions

Ten. Packing List

One. Brief Introduction

iRock-439T Automatic Rockwell hardness tester with a good aesthetic aspect, complete functions, easy operation, intuitive display and good reliability, is a high-tech product combining the mechanic and electric features, which is suitable for the Rockwell and superficial Rockwell hardness test.

1. Support for all the Rockwell and superficial Rockwell scales;
2. Support for conversion scales of different kinds of hardness;
3. With arc correction function;
4. Touch screen display and operation, dynamically display the working state of the lifting screw and the indenter;
5. Press operation for the test table, fast rising or dropping;
6. One key to complete the rising of the specimen, loading dwell and unloading of the indenter, displaying of the hardness value, homing of the test table;
7. With data storage function, automatic calculation of the maximum, minimum, average of the hardness value, the test results can be printed for output, and with a RS232 interface users can connect it to the computer for output.
8. Suitable for quenched steel, tempered steel, annealed steel, cold and hard casting, malleable cast iron, hard alloy steel, aluminum alloy, copper alloy, bearing steel etc. Also suitable for surface quenched steel, surface heat treating and chemical treating materials, sheet, zinc layers, chrome layers, tin layers etc.

Two. Main Parameters

Model	iRock-439T
Initial Test Force	3kgf (29.42N), 10kgf (98.07N)
Total Test Force	15kgf (147.1N), 30kgf (294.2N), 45kgf (441.3N), 60kgf (588.4N), 100kgf (980.7N), 150kgf (1471N)
Indenter	Diamond Rockwell Indenter, Φ 1.588mm Ball Indenter
Loading Method	Automatic (Loading/Dwell/Unloading)
Operation	Automatic Rising and Homing, One Key to Complete
Hardness Reading	Touch Screen
Test Scale	HRA, HRD, HRC, HRFW, HRBW, HRGW, HRHW, HREW, HRKW, HRL, HRM, HRP, HRR, HRS, HRV HR15N, HR30N, HR45N, HR15TW, HR30TW, HR45TW, HR15W, HR30W, HR45W, HR15X, HR30X, HR45X, HR15Y, HR30Y, HR45Y
Conversion Scale	HV, HK, HRA, HRBW, HRC, HRD, HREW, HRFW, HRGW, HRKW, HR15N, HR30N, HR45N, HR15TW, HR30TW, HR45TW, HS, HBW
Data Output	Built-in Printer, RS232 Interface
Hardness Resolution	0.1HR
Dwell Time	0~99s
Max. Sample Height	310mm
Throat Depth	150mm
Power Supply	AC220V, 50Hz
Execute Standard	ISO 6508, ASTM E18, JIS Z2245, GB/T 230.2
Dimension	535×330×890mm, Packing Dimension: 820×460×1170mm
Weight	Net Weight: 80kg, Gross Weight: 100kg

Three. External Structure

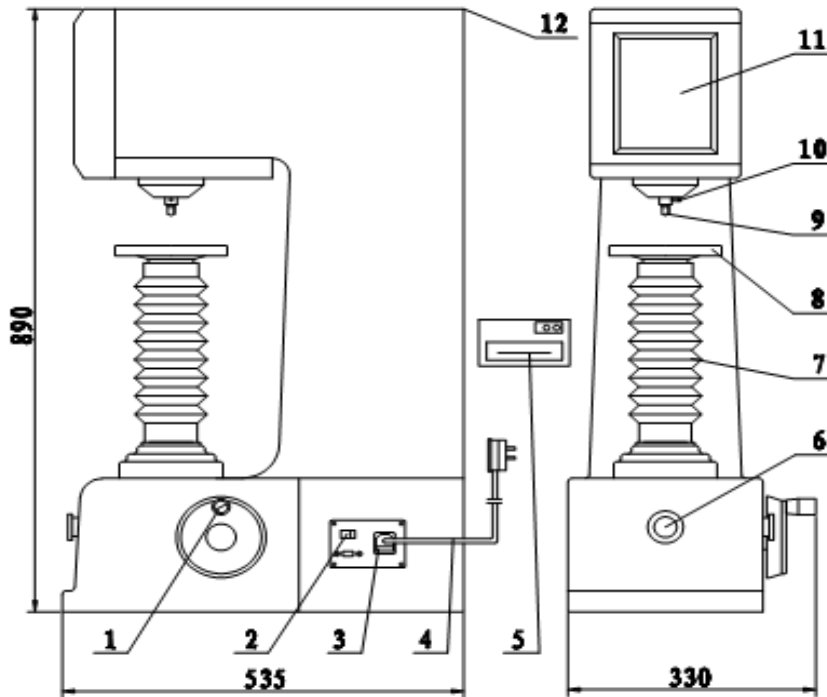

1. Hand wheel	2. Power switch	3. Fuse	4. Power cable
5. Printer	6. Emergency stop button	7. Lifting screw	8. Test table
9. Indenter	10. Fasten screw	11. Touch screen	12. Upper cover

Four. Working Condition

1. Under the room temperature between 10~30°C.
2. The relative humidity of the room is inferior to 65%.
3. Placed on a stable table, free from vibration and without corrosive agent in surroundings.
4. Connect the stable voltage power supply with good grounding.

Five. Unpacking and Installation

1. Cut the belts on the packing box.
2. Loosen the screws on the middle bottom iron sheet on both sides of the case.
3. Lift the case up and you can see the machine; take out the accessory box and dust cover.

4. Unscrew the two M10 bolts under the bottom plate with a spanner.
5. Lift the hardness tester and place it on the prepared stable table (suggested height 450mm).

There should be a hole on the table as following proposal:

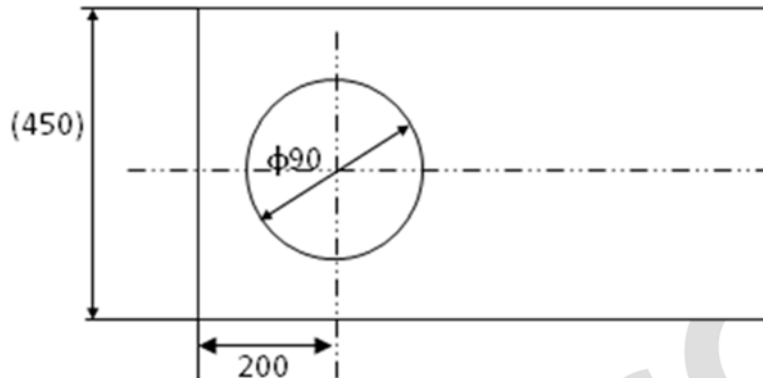

6. Remove the straps on the lifting screw and hand wheel.
8. Take out the test table and install it on the lifting screw.
9. Take out the power cable and connect it to the power.

Six. Operation Procedure

1. Turn on the power switch, and the touch screen shows the main interface.

2. Press  to select the scale.
3. Choose the corresponding indenter, push the indenter to the main shaft hole, close to the bearing surface, face the notch plane of the indenter handle to the screw, and tighten the fasten screw slightly.

4. Press  to set the dwell time, arc correction and upper and lower limit etc.

5. Wipe the test sample clean, place it at the edge of the test table, and then slowly push it under the indenter.

6. Press  to make the test sample close to the indenter, adjust the test position



of the sample and then press  to start the test.

7. The machine will automatically apply the loading, dwelling and unloading, and then show the hardness result.

8. The test table automatically descends and the test is completed.

9. The first result for Rockwell is not valid, adjust the sample position and press the start key again, the machine will automatically finish the test and show the test result.

Seven. Interface Introduction and Usage

1. Main interface function:

The screenshot shows the main control interface of the iqualitrol machine. It features a large digital display at the top showing '50.0' and 'HRC'. Below the display is a graph area with 'F/Kg' on the y-axis and 'T/s' on the x-axis. To the right of the graph are several control buttons: a dwell time button showing '5 S', a scale selection button with a double arrow, a qualification button with a double arrow, a 'Delete current' button with a trash icon, a 'Check all' button with a folder icon, and a 'Start' button with a blue play icon. At the bottom are 'Set' and 'Help' buttons. Callout boxes on the right side of the image point to these various elements.

- Date and time
- Hardness result
- Scale selection
- Dwell time
- Scale
- Qualification
- Delete current
- Check all
- Start

Press the up and down arrows to rise and descend the test table. The double arrows are quick rise and quick descend.

The test force and displacement window shows the real-time changes of the force sensor and displacement sensor of the instrument.

The hardness value window displays the latest 6 groups of hardness results. Press the folder to view all the data, select to print or delete, and it automatically calculates the maximum, minimum and average values.

Press Set to set the dwell time, arc correction, qualification judge, etc.

Press Help to view the operation procedure, precautions, indication adjustment, etc.

2. Set interface:

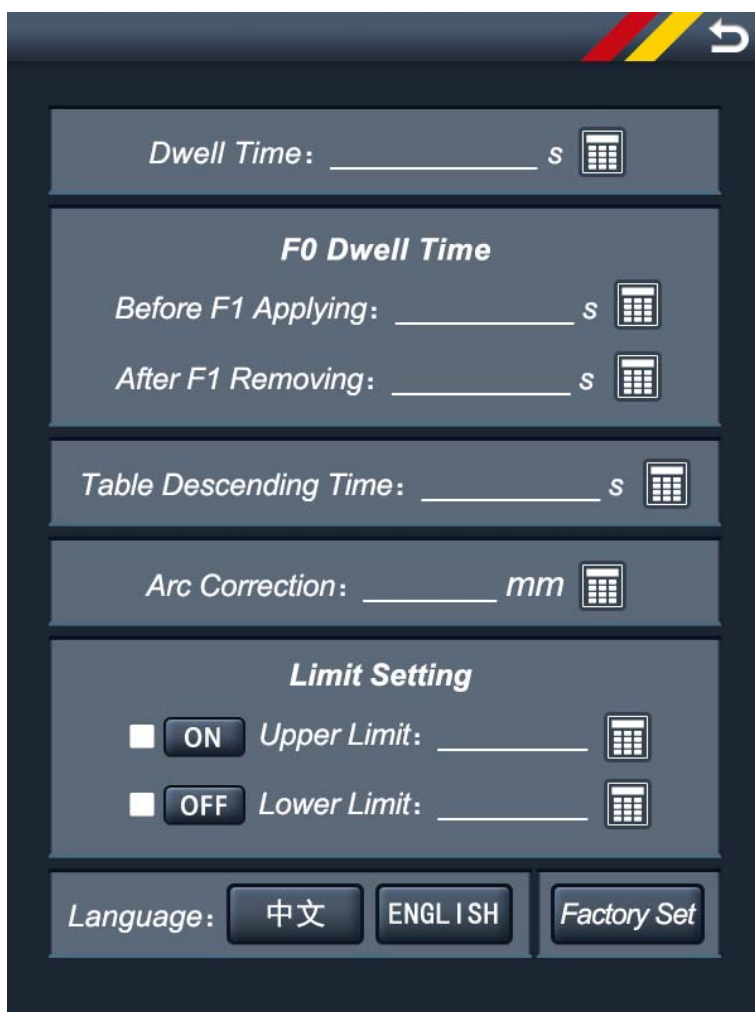



Dwell Time is the dwell time setting of the total test force.

F0 Dwell Time of the preliminary test force can be set separately according to the national standard.

Table Descending Time represents the time of table descent after unloading the test force, which can basically control the height of table descent.

The hardness value of the cylinder sample can be corrected by Arc Correction.

Limit Setting can be set for qualification judge. The hardness value beyond the range will be displayed in red font,  and  will be prompted.

The Factory Set is for factory debugging, and users do not need to set it.

3. Help interface:

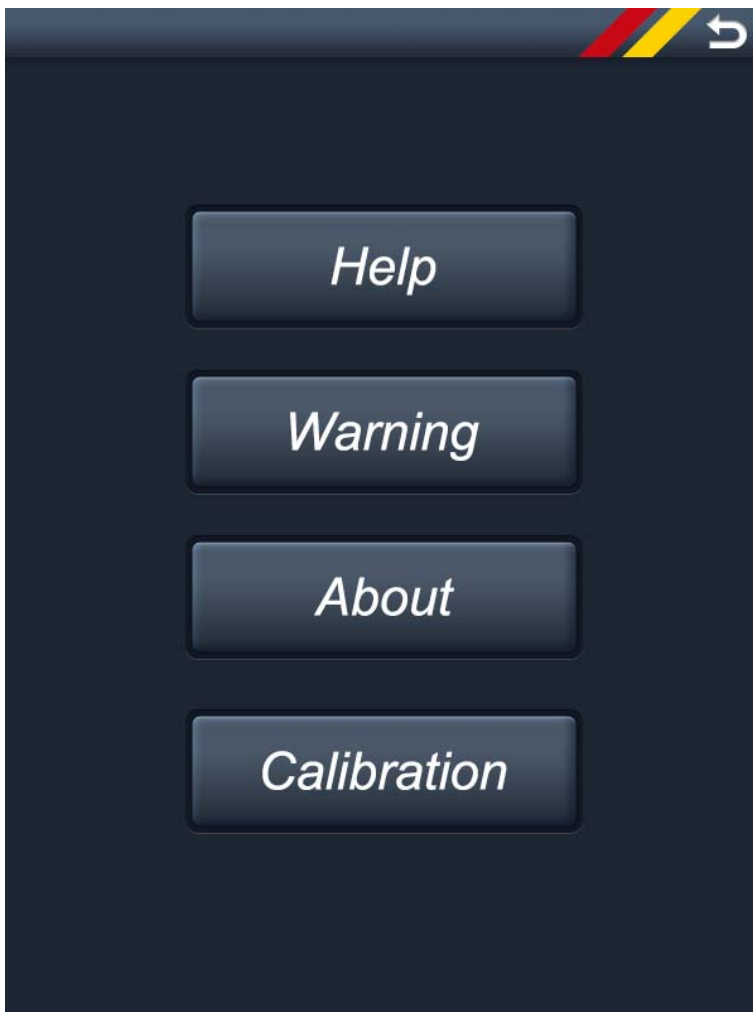

Press Help to check the operation tips, operation procedure, instrument parameters, Rockwell and superficial Rockwell hardness related information.

Press Warning to see the precautions for using the instrument.

Press About to know the executive standard and version number of the instrument.

Press Calibration to do the software calibration of the hardness result.

Eight. Attached List

1. Technical specifications of Rockwell hardness

Test Force	Initial Test Force(N)	98.07 (10kg)			Tolerance $\pm 2.0\%$
	Total Test Force(N)	588.4 (60 kg)			Tolerance $\pm 1.0\%$
		980.7 (100 kg)			
		1471 (150kg)			
Indenter	Diamond Cone Indenter				
	$\Phi 1.5875$ mm Ball Indenter				
Scale	HRA	HRBW	HRC	HRD	HREW
	HRFW	HRGW	HRHW	HRR	HRM
	HRP	HRS	HRKW	HRL	HRV

2. Allowed tolerance and repeatability of Rockwell hardness

Scale	Hardness Range of Standard Hardness Blocks	Allowed Tolerance of Displaying Value	Allowed Repeatability of Displaying Value ^a
A	20~ \leq 75HRA	± 2 HRA	$\leq 0.02(100-H)$ or 0.8 Rockwell unit ^b
	> 75 ~ \leq 95HRA	± 1.5 HRA	
B	10~ \leq 45HRB	± 4 HRB	$\leq 0.04(130-H)$ or 1.2 Rockwell unit ^b
	> 45 ~ \leq 80HRB	± 3 HRB	
	> 80 ~ \leq 100HRB	± 2 HRB	
C	10~ \leq 70HRC	± 1.5 HRC	$\leq 0.02(100-H)$ or 0.8 Rockwell unit ^b
a: H means average hardness value		b: select a larger value	

The normally used Rockwell hardness scales are A, B, C 3

3. The scales, indenters, test force and application examples of Rockwell hardness test

Scale	Indenter	Initial Test Force (N)	Total Test Force (N)	Application Examples
HRA	Diamond Indenter	98.07 N (10kg)	588.4(60kg)	Hard metal and hard alloy
HRD			980.7(100kg)	Steel sheet, surface-quenched steel
HRC			1471(150kg)	Heat treated structural steel, tool steel
HRFW	Ball Indenter φ1.5875mm (1/16 inch)		588.4(60kg)	Non-ferrous metals
HRBW			980.7(100kg)	Non-ferrous metals; soft metals
HRGW			1471(150kg)	Pearlite iron, copper, nickel, zinc alloy
HRHW	Ball Indenter φ3.175mm (1/8 inch)		588.4(60kg)	annealed copper alloy
HRKW			1471(150kg)	Non-ferrous metals, hard plastics
HREW			980.7(100kg)	Aluminum and aluminum alloy
HRL	Ball Indenter φ6.35mm (1/4 inch)		588.4(60kg)	
HRM			980.7(100kg)	
HRP			1471(150kg)	
HRR	Ball Indenter φ12.7mm (1/2 inch)	588.4(60kg)		
HRS		980.7(100kg)		
HRV		1471(150kg)		

4. Technical specifications of superficial Rockwell hardness

Test Force	Initial Test Force(N)	29.42 (3 kg)			Tolerance $\pm 2.0\%$
	Total Test Force(N)	147.1 (15 kg)			Tolerance $\pm 1.0\%$
		294.2 (30 kg)			
		441.3 (45 kg)			
Indenter	Diamond Cone Indenter, $\Phi 1.5875\text{mm}$ Ball Indenter				
Scale	HR15N	HR15T	HR15W	HR15X	HR15Y
	HR30N	HR30T	HR30W	HR30X	HR30Y
	HR45N	HR45T	HR45W	HR45X	HR45Y

5. Allowed tolerance and repeatability of superficial Rockwell hardness

Scales	Hardness Range of Standard Hardness Blocks	Allowed Tolerance of Displaying Value	Allowed Repeatability of Displaying Value ^a
15N	70~77 HR 15N	± 2 HRN	$\leq 0.04(100-H)$ or 1.2 Rockwell unit ^b
	78~88 HR 15N		
	89~91 HR 15N		
30N	42~54 HR 30N		
	55~73 HR 30N		
	74~80 HR 30N		
45N	20~31 HR 45N		
	32~61 HR 45N		
	63~70 HR 45N		
15T	73~80 HR 15T	± 3 HRT	$\leq 0.06(100-H)$ or 2.4 Rockwell Unit ^b
	81~87 HR 15T		
	88~93 HR 15T		
30T	43~56 HR 30T		
	57~69 HR 30T		
	70~82 HR 30T		
45T	12~33 HR 45T		
	34~54 HR 45T		
	55~72 HR 45T		
a: H means average hardness value		b: select a larger value	

The normally used superficial Rockwell hardness scales are N, T

6. The scales, indenters, test force and application examples of superficial Rockwell hardness test

Scales	Indenters	Initial Test Force (N)	Total Test Force (N)	Application Examples
15N	Diamond Indenter	29.42 N (3kg)	147.1(15kg)	Hard alloy steel, nitride steel, carburized steel, various heavy steel plate, etc
30N			294.2(30kg)	Surface-quenched steel, carburized steel, knife, thin steel plate, etc
45N			441.3(45kg)	Quenched steel, tempered steel, hard cast iron and edge of parts, etc
15T	Ball Indenter φ1.5875mm (1/16 inch)		147.1(15kg)	Annealed copper alloy, mild steel sheet, brass, bronze plate, etc
30T			294.2(30kg)	Mild steel sheet, aluminum alloy, copper alloy, brass and bronze, malleable cast iron
45T			441.3(45kg)	Pearlite iron, copper -nickel alloy and zinc-nickel alloy plate, etc
15W	Ball Indenter φ3.175mm (1/8 inch)		147.1(15kg)	Annealed copper alloy, mild steel, etc
30W			294.2(30kg)	Aluminum and aluminum alloy, magnesium mild steel, etc
45W			441.3(45kg)	Zinc, aluminum, lead, bronze, beryllium bronze, etc
15X	Ball Indenter φ6.35mm (1/4 inch)		147.1(15kg)	Aluminum, tin, zinc, soft metals, plastics, hard cardboard, etc
30X			294.2(30kg)	
45X			441.3(45kg)	
15Y	Ball Indenter Φ12.7mm (1/2 inch)		147.1(15kg)	Aluminum, tin, zinc, soft metals, plastics, hard cardboard, etc
30Y			294.2(30kg)	
45Y			441.3(45kg)	

7. Min. thickness of the specimen

The Min. thickness of the specimen should be 10 times superior to the depth of the indentation. After the test, the back of the specimen should not have any visible signs of deformation.

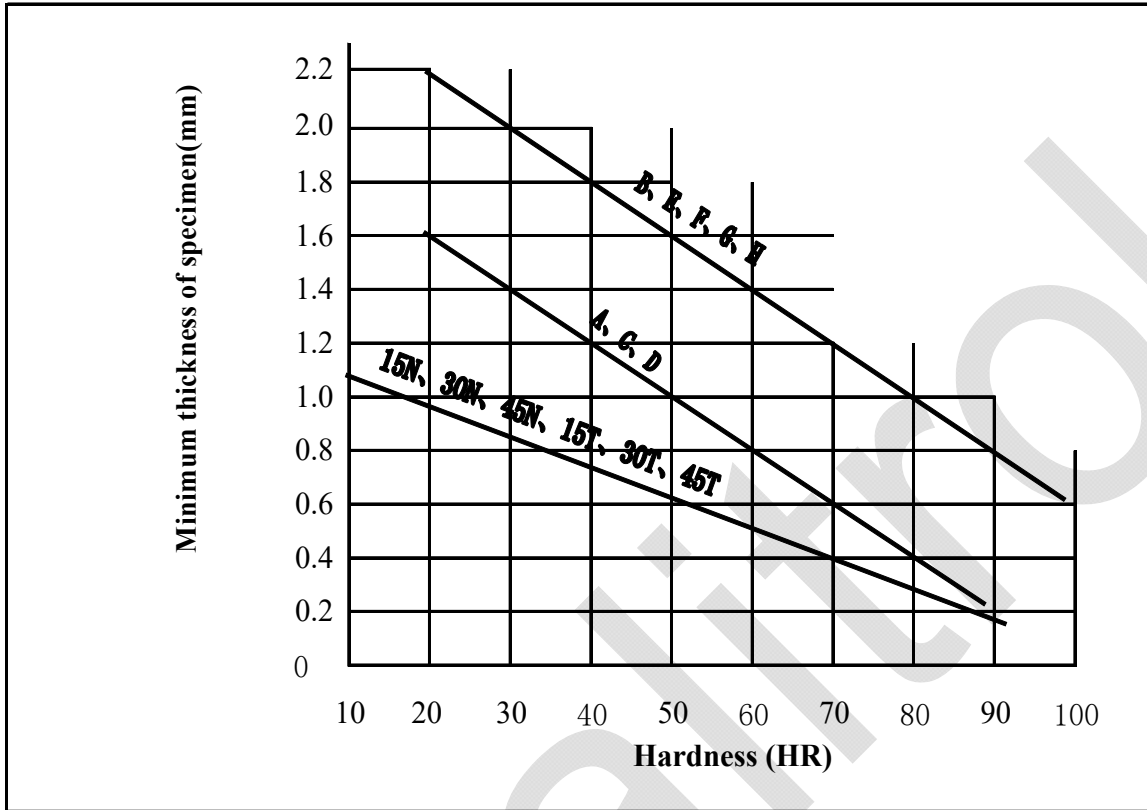

8. Arc correction

When test Rockwell hardness value with HRC and HRA scales, the diameter of specimen to be tested is less than 38mm or when test with HRBW scale, the diameter of specimen to be tested is less than 25mm, the results of the test should be revised. The revised values are all positive numbers.

Hardness Value	Diameter of the Columned Specimen (mm)								
	6	10	13	16	19	22	25	32	38
HR	Modified Value of Rockwell Scales A, B, C (HR)								
20				2.5	2.0	1.5	1.5	1.0	1.0
25			3.0	2.5	2.0	1.5	1.0	1.0	1.0
30			2.5	2.0	1.5	1.5	1.0	1.0	0.5
35		3.0	2.0	1.5	1.5	1.0	1.0	0.5	0.5
40		2.5	2.0	1.5	1.0	1.0	1.0	0.5	0.5
45	3.0	2.0	1.5	1.0	1.0	1.0	0.5	0.5	0.5
50	2.5	2.0	1.5	1.0	1.0	0.5	0.5	0.5	0.5
55	2.0	1.5	1.0	1.0	0.5	0.5	0.5	0.5	0
60	1.5	1.0	1.0	0.5	0.5	0.5	0.5	0	0
65	1.5	1.0	1.0	0.5	0.5	0.5	0.5	0	0
70	1.0	1.0	0.5	0.5	0.5	0.5	0.5	0	0
75	1.0	0.5	0.5	0.5	0.5	0.5	0	0	0
80	0.5	0.5	0.5	0.5	0.5	0	0	0	0
85	0.5	0.5	0.5	0	0	0	0	0	0
90	0.5	0	0	0	0	0	0	0	0

Hardness Value	Diameter of the Columned Specimen (mm)							
	6	10	13	16	19	22	25	
HR	Modified Value of Rockwell Scales B, F, G (HR)							
20					4.5	4.0	3.5	3.0
30				5.0	4.5	3.5	3.0	2.5
40				4.5	4.0	3.0	2.5	2.5
50				4.0	3.5	3.0	2.5	2.0
60		5.0		3.5	3.0	2.5	2.0	2.0
70		4.0		3.0	2.5	2.0	2.0	1.5
80	5.0	3.5		2.5	2.0	1.5	1.5	1.5
90	4.0	3.0		2.0	1.5	1.5	1.5	1.0
100	3.5	2.5		1.5	1.5	1.0	1.0	0.5

When test superficial Rockwell hardness value, the diameter of specimen to be tested is less than 25mm, the results of the test should be revised. The revised values are all positive numbers.

Hardness Value HRN	Diameter of the Columned Specimen (mm)					
	3.2	6.4	10	13	19	25
	Modified Value of superficial Rockwell Scale HRN					
20		3	2	1.5	1.5	1.5
25		3	2	1.5	1.5	1
30		3	2	1.5	1	1
35		2.5	2	1.5	1	1
40		2.5	1.5	1.5	1	1
45		2	1.5	1	1	1
50		2	1.5	1	1	1
55		2	1.5	1	0.5	0.5
60	3	1.5	1	1	0.5	0.5
65	2.5	1.5	1	0.5	0.5	0.5
70	2	1	1	0.5	0.5	0.5
75	1.5	1	0.5	0.5	0.5	0
80	1	0.5	0.5	0.5	0	0
85	0.5	0.5	0.5	0.5	0	0

Hardness Value HRT	Diameter of the Columned Specimen (mm)						
	3.2	6.4	10	13	16	19	25
	Modified Value of superficial Rockwell Scale HRT						
20						3	2
30						2.5	2
40					3	2.5	2
50				3	2.5	2	1.5
60			3	2.5	2	1.5	1.5
70			2.5	2	1.5	1	1
80	3	2	1.5	1.5	1	1	0.5
90	1.5	1	1	0.5	0.5	0.5	0.5

Nine. Precautions

1. The surface of the specimen should be smooth and clean without any feculence, oxidized peels, concaves and the outstanding machining signs. The supporting plane of specimen and the test table should be clean to assure a good smoothness between them.
2. The specimen should be stably fixed on the test table. There should be no movement during the testing process and the test force should be assured to load perpendicularly on the specimen.
3. If the specimen is columned, the V-shaped test table must be used.
4. During installation of the diamond cone indenter, the middle finger of hand should withstand the head of diamond, push the indenter forward to the indenter shaft hole slightly, avoid damaging the head part of diamond.
5. The operator should observe the operation regulations and calibrate the instrument with the standard hardness block before and after the test.
6. The standard hardness block should be used only on the working plane with the distance of the two neighboring indentations and distance of the center of the indentations to their edges are not inferior to 3 mm.
7. Carry out periodic inspection of the tester, at least once a year in order to assure the accuracy of the tester.
8. The adjustment of displaying hardness value:
 - The precision of the displaying hardness value of the tester is just calibrated before the instrument leaves the factory. If a tolerance is caused due to the transportation, the operator may regulate it based on the understanding of the instrument structure and principle.
 - Method 1: Remove the upper cover. If the measured value is lower than the standard hardness block, first fix the Screw Rod with an inner hexagon spanner, loosen the nut slightly, rotate the Screw in slightly clockwise, and then fix the Screw Rod and tighten the nut. Do the test again and adjust until the value stands in the tolerance range. If the measured value is higher than the hardness value of the standard block, rotate the Screw in the opposite direction

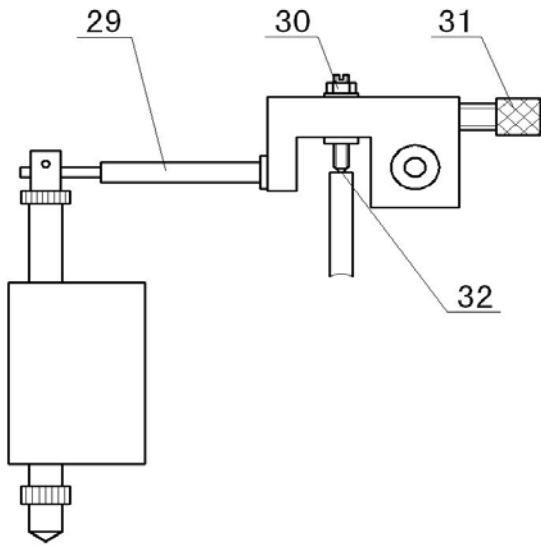

29. Connecting Rod

30. Screw Rod

31. Screw

32. Protecting Gasket

- Method 2: Press the "Help" button on the main interface, and press the hardness scale which should be corrected in "Calibration". Each scale has a hardness value range (at the top of the screen), which can be modified by up and down keys.

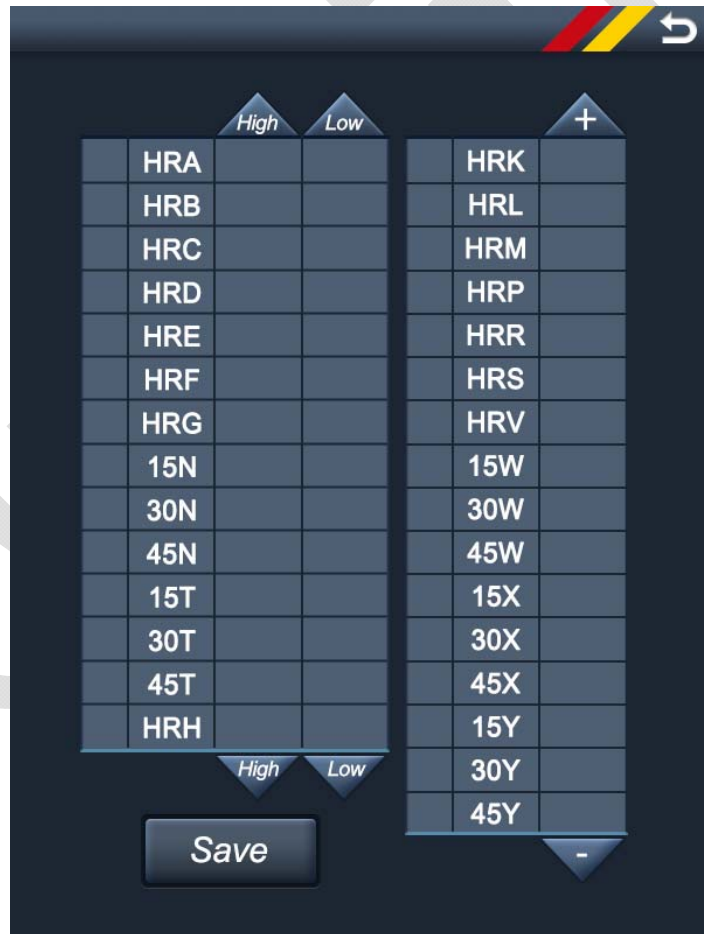

Ten. Packing List

Name	Qty	Name	Qty
Instrument Main Body	1 set	Diamond Rockwell Indenter	1 pc
Φ1.588mmBall Indenter	1 pc	Φ150mm Flat Anvil	1 pc
Φ60mm Flat Anvil	1 pc	Φ40mm V-shaped Anvil	1 pc
Hardness Block 60~70 HRC	1 pc	Hardness Block 20~30 HRC	1 pc
Hardness Block 80~100 HRBW	1 pc	Hardness Block 70~85 HR30TW	1 pc
Hardness Block 65~80 HR30N	1 pc	Fuse 2A	2 pcs
Inner Hexagon Spanner	1 pc	Spanner	1 pc
Power Cable	1 pc	Anti-dust Cover	1 pc
Usage Instruction Manual	1 copy		